



**Tarrant County Public Health Department
Environmental Health Promotion
1101 S. Main Street, Room 2300
Fort Worth, Texas 76104
Phone: (817) 321-4960 Fax: (817) 321-4961**

Temporary Food Establishment Permit Application

PLEASE COMPLETE & RETURN THIS FORM WITH FEE FOR EACH STAND AT LEAST 10 DAYS BEFORE THE START OF THE EVENT.

Fee Information: *(submit one of the following)*

- 1) \$35.00 for each stand or unit. *We are unable to accept credit/debit cards by phone or online.*
- 2) IRS 501 (c) (3) official recognition documentation for tax exempt charitable organizations.

General Event Information:

- 3) Name of Event: _____
- 4) Date(s) of Event: _____
- 5) Hours of Operation: _____
- 6) Location of Event: _____
- 7) Event Coordinator:
Name: _____ Phone: _____
Address: _____

Applicant Information:

- 8) Your Organization/Business Name: _____
- 9) Applicant's Name: _____
Address: _____
City: _____ State: _____ Zip: _____
Business Phone: _____ Home Phone: _____
Mobile Phone: _____ Fax: _____
Email: _____

- 10) Does this business have a current mobile food unit or pushcart permit from the Tarrant County Health Department? Yes No
If yes, what is the permit type and site number? _____

Note: Vendors with these types of health permits are not required to pay the permit fee for a temporary food service establishment.

- 11) List full menu to be served at the event: _____

12) Where will the food be purchased/obtained from: _____

13) Will any foods be prepared prior to the start of the event? Yes No
If yes, where will the food be prepared? _____

If answering yes to question 11, all foods prepared prior to the event are required to be made in an approved and permitted facility. A copy of the Food Establishment Permit and signed Commissary Agreement (attached) are required for approval of this application. Applications submitted without this information will be returned.

Has a copy of the Food Establishment Permit and signed Commissary Agreement been included with this application? Yes No N/A

14) Will frozen foods be thawed at the event? Yes No
If yes, describe process/method to be used: _____

15) How will any leftovers of cooked food be handled at the end of the day?

16) How will food temperatures be checked during the event? _____

17) Describe equipment used at the event for:
a) Cold holding: _____
b) Hot holding: _____
c) Cooking/Reheating: _____

18) Describe hand washing facilities inside your temporary food establishment:
 Plumbed Sink Gravity Flow Set-up

19) Describe utensil washing facilities inside your temporary food establishment:
 3 Compartment Sink 3 Basin Set-up

20) How will hot water be made available for the hand wash and utensil washing stations?

21) What type of sanitizer will be used at the event? _____

22) How will potable water be obtained during the event? _____

23) How will waste water from hand & utensil washing be disposed? _____

Form completed by: _____

Name/Title

Date

FOOD HANDLERS:

Avoid food handling when you have the following symptoms.



- Diarrhea.
 - Vomiting.
 - Sore throat with fever.
 - Persistent coughing, sneezing or nasal discharge.
 - Wound containing pus upon your fingers, hands, wrists.
 - Yellowish eyes or skin with dark colored urine.
- Report any of these symptoms to your manager immediately.



Personnel that handle food must wash their hands as frequently as necessary. Disposable gloves may be used but their use does not substitute for hand washing.

The use of tobacco in all forms is prohibited in the food preparation or service areas.

Personnel shall not eat or drink in the food preparation or service areas.

Hair restraints and clean clothing are required of personnel doing food preparation. Food handlers are not permitted to wear ornate hand jewelry.

Unauthorized personnel such as small children are not permitted in booths.

BARE HAND CONTACT:

Bare hand contact of ready to eat food by workers is not allowed.

Ready-to-eat food includes any food, fruit or vegetable product that is edible without washing, cooking, or additional preparation by workers, and is reasonably expected to be consumed in that form.

Avoid touching food with bare hands by using utensils, disposable gloves, deli tissue or other suitable methods.

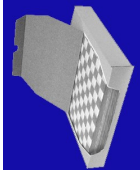
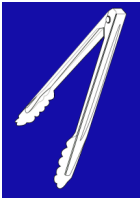

CHECKLIST:

- Valid temporary or mobile food unit permit issued by Tarrant County Public Health Department.
- Food from an approved source. No food prepared in a private home. *Food invoices/receipts must be available at booth for inspector's audit.*
- Adequate supply of potable water at booth.
- Waste water containers and proper disposal site.
- Booths with cleanable floor (*grass and dirt covered with approved material*) and overhead protection.
- BBQ and deep-frying cooking areas fenced off from public access.
- Adequate containers, covers, wrappings or other means to effectively protect food from insects and other environmental contamination.
- Hand wash station setup and ready for use.
 - 5 gal. container with non-self-closing spigot.
 - Liquid soap in pump dispenser.
 - Paper towels.
 - Wastewater catch bucket.
- Utensil cleaning station setup and ready for use.
 - 3 containers (*sized to immerse all items*)
 - Soapy water in 1st container.
 - Clean rinse water in 2nd container.
 - Sanitizing solution in 3rd container.
 - Sanitizer concentrate (*bleach*) and test strips.
- Enough equipment provided to hold ALL:
 - Cold foods at 41°F or below.
 - Hot foods at 135°F or above.
- Probe-type, metal stem food thermometer with proper range (*0°F to 220°F*).
- Utensils and disposable gloves provided to minimize hand contact with food.
- Workers are wearing clean clothing and hair is effectively restrained.
- Workers have no open sores and are free of illness symptoms listed in brochure.
- Workers keep hands clean and wash hands frequently.
- No bare hand contact with ready to eat food.
- Condiments provided in single-service, pump-type or squeeze containers.
- Sneeze guards and barriers to protect exposed food and food work surfaces from customers.

Temporary Food Establishment Requirements



Tarrant County Public Health Department

1101 S. Main St., Room 2300

Fort Worth, Texas 76104

817-321-4960

TEMPORARY FOOD ESTABLISHMENT:

The term temporary food establishment applies to an establishment that operates at a fixed location for a period of time of not more than 14 consecutive days in conjunction with a single event or celebration.

PERMIT REQUIRED:

Persons vending or offering samples of food or beverage products must secure a valid Tarrant County Health Department permit prior to operation. Permits issued by other health authorities are not acceptable.

Vendors handling only commercial pre-packaged, shelf-stable, non-potentially hazardous foods do not need a permit.

CONSTRUCTION OF STAND:

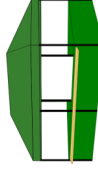

All stands must have a suitable tight-fitting, water repellent roof or ceiling to provide for overhead protection of food preparation, cooking and serving areas.

All stands must have approved flooring, which includes concrete, asphalt or tight-fitting plywood or other similar approved material.

If full walls and screening are provided, other suitable methods of protecting food from contamination, such as containers, covers or wrappings must be used.

Adequate covered receptacles for disposal of solid waste must be provided.

Adequate toilet facilities must be accessible for workers.

WATER SUPPLY & WASTE WATER DISPOSAL:

Potable water must be from an approved source and kept on-site in sufficient quantities for each day's use.

All waste water generated from the temporary food establishment (from beverage dispensers, sinks, steam tables, ice melt, etc.) must be disposed of into the sanitary sewer system or approved septic system.

UTENSIL WASHING:

Those stands that do not have 3-compartment sinks with hot and cold running water must provide the following:



Three (3) sturdy plastic or stainless steel buckets or tubs of adequate size to be used for utensil cleaning and sanitizing.

One bucket or tub shall be used to wash (soapy water);

One bucket or tub shall be used to rinse (clean, clear water);

One bucket or tub shall be used to sanitize (liquid chlorine bleach/water solution with 2 teaspoons of bleach per gallon water). Use chlorine test strip to verify proper strength of 50 to 100 ppm.

HANDWASHING:

Soap, paper towels and a container (5 gallon minimum) with a spigot that remains open to wash both hands shall be provided for hand washing.

Containers with self-closing spouts are not acceptable.

In addition, a bucket to catch waste water shall be provided.

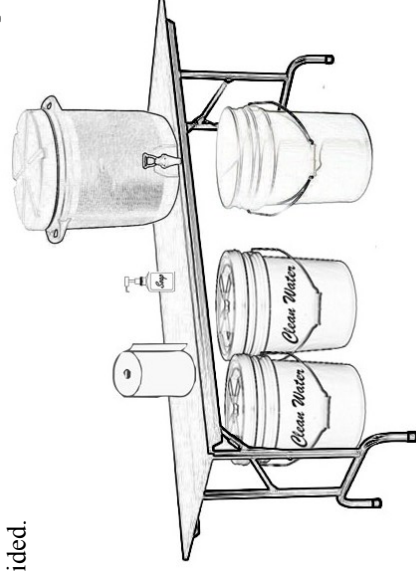

FOOD PREPARATION:

All foods must be from an approved source and/or licensed facility or prepared in the temporary booth.

An approved source is an establishment that is under inspection and/or licensed by a health authority.

NO foods prepared in a private home may be sold or served to the public.



Only single-service, disposable items are to be provided for customer use.

All foods, food containers, utensils, napkins, beverage cups, straws and other single service items must be stored at least six inches above the floor and protected from splash, dust, insects, weather or other contamination.

All potentially hazardous food products must be stored at 41°F or lower or at 135°F or above. A metal stem product thermometer (0° F to 220° F) must be available at the stands that sell potentially hazardous foods.

Self-service of ice by patrons is not permitted. Ice scoops must be used by workers to dispense ice. Ice for human consumption must be stored separately from ice used to chill other foods or beverages.

Foods and beverages chilled in ice must not be submerged in water. The ice storage unit must have open drains and covers. Styrofoam ice chests are not acceptable for the storage of ice or other foods products.

All condiments, including onions, relish, catsup, mustard, mayonnaise, etc., available for customer self-service must be available in single self-service packets or properly dispensed from sanitary dispensers.



Customer self-service of open condiments from containers, even if provided with lids, is not allowed.

